

OTEC SF-HP SUPER HEAVY DUTY WITH INTEGRATED LOADING SYSTEM



STREAM FINISHING SOLUTION WITH AUTOMATED LOADING AND SETUP

With the SF-HP, large, heavy workpieces can be smoothed, rounded and deburred with absolute process reliability, fully automatically and with extremely short process times of just a few minutes. It can accommodate a wide variety of workpiece sizes in a single operation without violating the workpiece contours significantly. The SF-HD is ready for process automation thanks to its integrated, fully automatic loading system.



Read more

Sectors

Aerospace, mechanical engineering, tools; energy, oil and gas industries, shipbuilding and the food industry

Highlights

- Fully automatic workpiece pickup and return
- Automatic setup of the spindle position and processing angle
- Simple part programming and part feeding via workpiece trolley
- Ready for automation: communication interface for robots

Properties

- 15" Siemens Touch HMI, adjustable via swivel arm
- Loading area for up to two workpieces
- Cyclical operation:
machine can be loaded and unloaded during processing
- Spindle with workpiece step function:
Workpiece can be freely positioned as required for processing
- Parameter monitoring and documentation
- Integrated, automatic workpiece cleaning



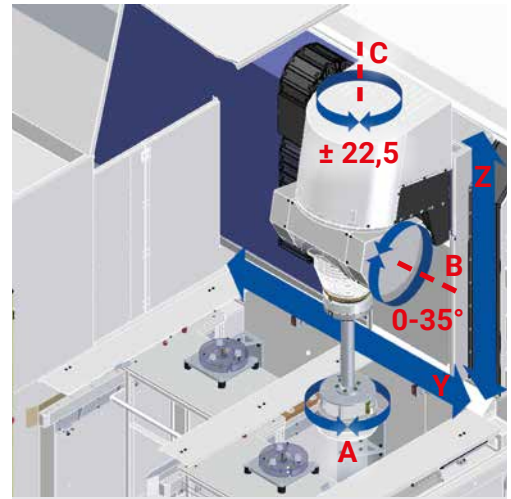

Technical features

Process parameters

- Max. workpiece dimensions (including holder): 200 kg, Ø up to 900 mm, L = 650 mm
- Spindle speed: up to 260 rpm

Operation

- Process selection via HMI or barcode scanner
- Simple spindle teach-in function for part programming
- Possibility of exchanging the process container

Equipment

- Heavy-duty zero point clamping system
- Part feeding via workpiece trolley
- Automatic lubrication system
- Automatic process water dosing
- Automatic loading door on the side of the machine

Automatic fitting of the spindle position

- Fully automatic immersion angle adjustment of 0 - 35°
- Fully automatic C angle adjustment (distance to the container wall) +/- 22,5°
- Fully automatic Z and Y axes
- Automatic setup of the spindle position when changing to another workpiece size



Try our OTEC Finishing Centre. We can develop custom solutions to suit your specific requirements.



Your contact person

Adrian Kofler (M. Eng.)
 Product & Business Development Manager
 +49 7082 4911 20
 a.kofler@otec.de

As a trusted global partner for perfect surfaces, OTEC builds innovative finishing machines which set high standards and achieve perfect process reliability. Revolutionising manual processing applications results in precise and consistent quality in the shortest possible process time.

Smooth surfaces every time, defined rounding results, the removal of burrs and a perfect sheen are decisive competitive advantages in almost all industrial sectors. In particular that means saving energy as well as extending the service life and increasing the durability of parts.

OTEC machines with the "Made in Germany" seal of quality stand for dependable technology, high-quality workmanship, reliable operation and a long service life.



OTEC Präzisionsfinish GmbH
 Heinrich-Hertz-Straße 24
 75334 Straubenhardt-Conweiler
 Germany +49 7082 4911 711
 sales@otec.de
 www.otec.de

Made
 in
 Germany